



Date: 23 July 2005

From: Gregg Smith, Rangemaster

To: All Action Pistol Competitors

Re: Cardboard Targets

Some discussion has been circulating regarding permissible cardboard targets for our Action Pistol Matches. I'll be the first to admit I re-opened this discussion after hours spent cutting cardboard. For those of you that shoot with me in the monthly matches I'll just say that I have no more expertise with a Stanley knife than I have with a rifle (those are those long things, right?).

Some thought come to mind regarding our standard W-B target:

1. Yes, it's a pain to hack out all the cardboard, but we have been lucky to have "free" target material all these years.
2. It is very time-consuming to cut these things out but putting the scoring rings (ok, Jeff, *rectangles*) only takes a few seconds per target. We have jigs for cutting W-Bs and penciling scoring zones.
3. I haven't had any volunteers to help cut them out and my time is as valuable to me as yours is to you; I'd rather invest the time in promoting the program and designing stages.
4. IPSC/IDPA cardboard targets cost money, but dimensionally are similar to the W-B.
5. After an exhaustive search of the *Action Pistol Range Safety Manual* (course book) there is no requirement that we use the W-B target.

The W-B target was designed by two of our members primarily as a target for neutralization (a total of 7 points). It has served us well and will continue to do so in the years to come.

All that being said I'd like to start using some (emphasis on *some*) IPDA or IPSC targets, with our scoring zones (we flip the target over and use the reverse side).

This does not mean we're going to be affiliated with IDPA or IPSC; as our President has pointed out (and I agree) we do not have the range space or infrastructure at this time to affiliate and hold productive matches.

IDPA targets are brown on both sides – IPSC targets have one brown side and one white side. Dimensionally here's how they stack up:

DIMENSIONS

IPSC Metric Target

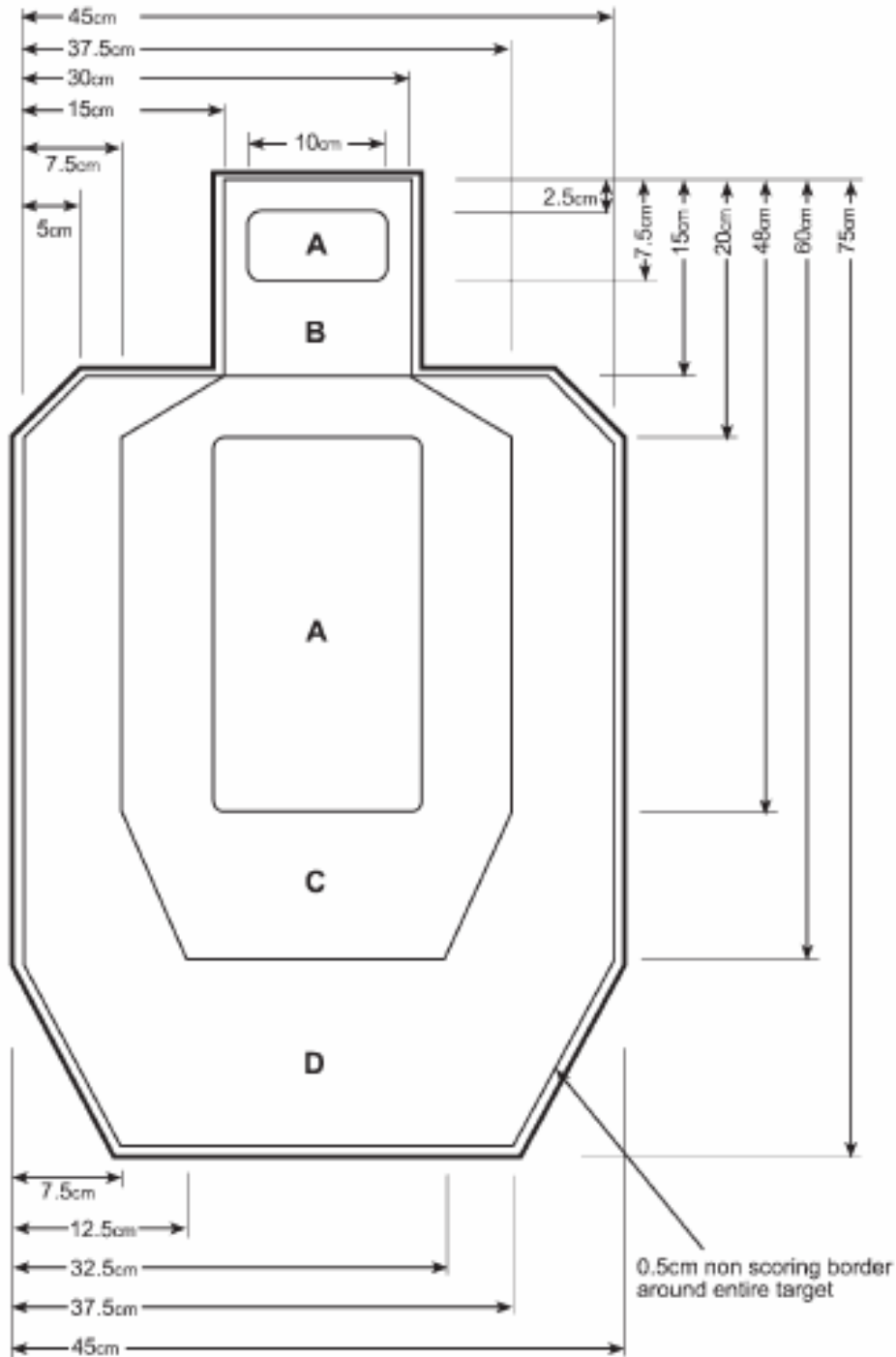

A. Official IDPA Target.

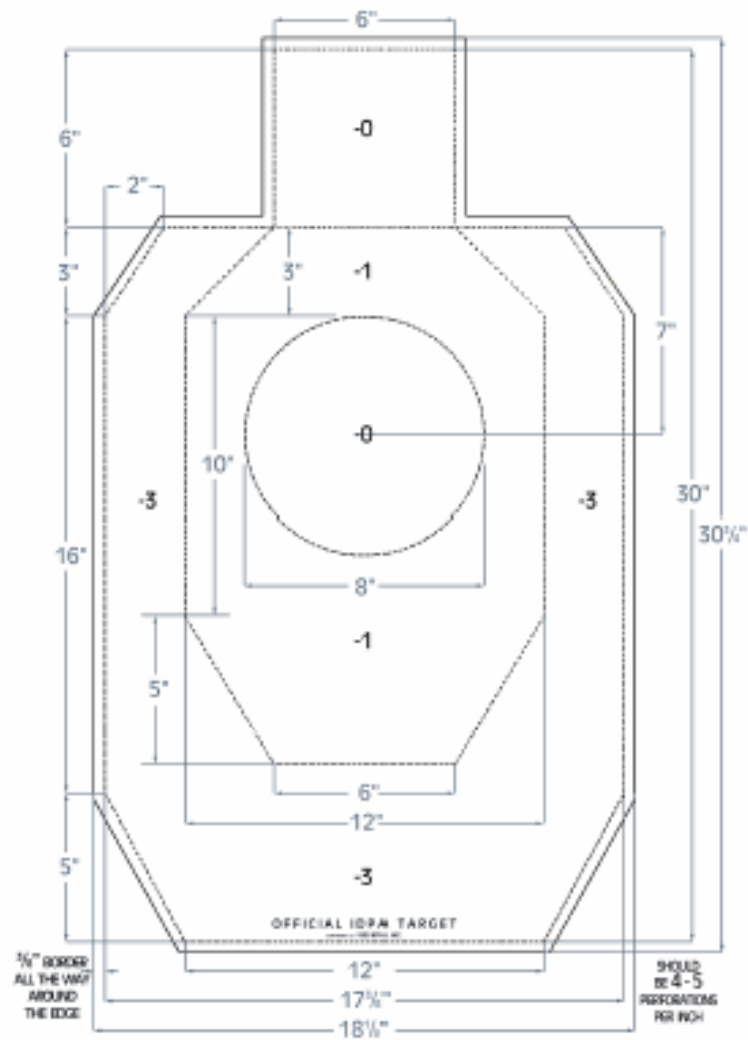

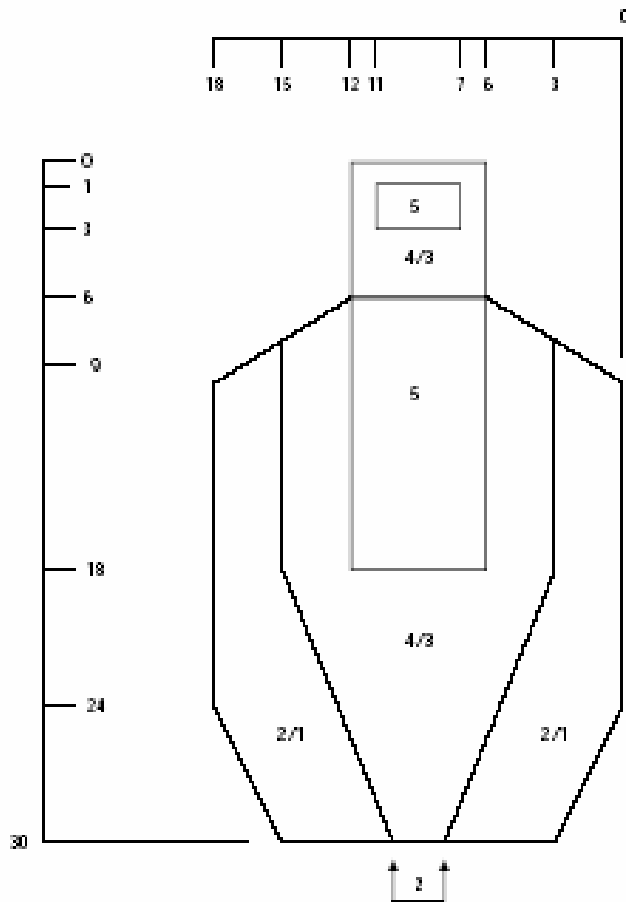

Note: All dimensions in inches.

W-B Target

- ✓ The W-B has a 6" x 6" head; the IPDA targets have a 6-3/4" x 6-3/8" head.
- ✓ The IDPA target is 18-1/8" wide x 30.75" tall, with a 3/8" non-scoring border; the W-B target is 18" wide x 30" tall, all a scoring area.
- ✓ The bottom of the IDPA is 12", so is the W-B.
- ✓ The "bottom cut" on IDPA is 5-3/8" x 3"; W-B is 6" x 3".
- ✓ The "shoulder cut" on IDPA is a 3" drop; so is the W-B.

A comparison of W-B to IPSC (the targets are more expensive than IDPA): overall IPSC dimensions are 17.7" wide x 29.52" tall. The head is 6.3" square. The bottom cut is 5.9" x 2.9"; the shoulder drop is only 2.165". The IPDA target is closer in size.

COST

Now for the cost side of the equation – at current prices the IDPA target (cheaper than the IPSC) runs about \$84/100 with shipping.

Target cost data:

Arizona Shooters - \$83.20/100

Target Barn - \$55/100 plus UPS

Alco Target - \$58/100 plus UPS 38 lbs (\$25.62) = \$83.62

Based on current projections we use 15 targets per match; with current attendance running about 15 shooters per match with 50 rounds per match and a target life of 50 rounds that's about \$1/shooter/match.

The thought occurred to someone that if we have pre-made targets (ok, we STILL have to put scoring zones on... a 20-second job) will we be inclined to use more targets? Gee...let me think... does that mean we would shoot more? You say that like it's a bad thing...

Another well-placed concern says "how long will it be until we just forget our scoring zones and use the IDPA ones...they're already marked". Good question. *I do not support using IDPA scoring zones at this time* – in reviewing the intent behind the W-B target I find the 5-zones closer to anatomically correct and conducive to more accurate shot placement.

PROPOSAL

1. We use IDPA targets (with our scoring zones) to supplement the W-B. It's not prohibited by current rules.
2. We raise the match fees. I propose \$12.00/members, \$14.00 non-members. If you're nuts about not carrying a bunch of one dollar bills I'll make a "pre-paid" Action Pistol punch card you can buy or just write a check.

The alternative is a work party every so often and you guys can help cut targets; I think that's a better idea but it's easier for most folks to pay two bucks more per match.

Gregg Smith
Rangemaster
Clatskanie Rifle & Pistol Club